

auto electrical parts

Technical Information Sheet

Part No. 0-420-85

Durite's powerful and compact 15W, 10-80 volt LED work lamp emitting a red line ideal for forklifts. 1700 Lumens. Diecast aluminum housing, supplied with stainless steel bracket. 6500K. Protected to IP68. I 75 x w 80 x h 87mm. CE Approved



Technical Drawing (not to scale)

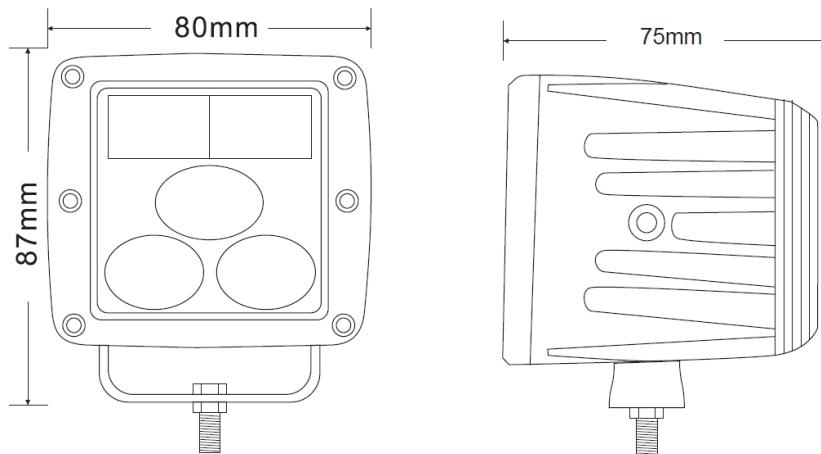

Specification

Type	LED Warning Lamp
Voltage	10-80VDC
LED's	5 x 3W (Epistar) 15W Max.
Lumens	1700 Lumens
Red Line Output Dimension	L 3.8M x W 30cm
Housing	Aluminium
Lens	PC
Degree of protection (IP)	IP68
Operating temperature	-40°C ~ 50°C
Weight	0.510Kg
Lifespan	30,000 Hours
Dimensions	Please see above diagram
Approvals	CE

The information contained in this document is correct to the best of our knowledge at the time of printing. However, specifications may change at any time without notice.